



Local: 863-614-1900 ★ Toll Free: 866-770-4930 ★ Fax: 888-782-3072
E-mail: telephoneman@telephonemanofamerica.com or Skype Us

TelephonemanOfAmerica.com or shop.telephonemanofamerica.com

TELEPHONE MAN OF AMERICA
Earning Your Business Every Step of the Way!

Specializing in Telecom Equipment of all Brands, Carrier Services, Technician Services, Maintenance Agreements and Purchasing Excess Telecom Equipment!

I will always do my best to match or beat any competitors bid!

DO NOT DISCARD THE BLANK DESIGNATION CARD

The voice terminal is shipped with a blank button designation card in place under the transparent cover. Do not discard this button designation card. Instead, place the preprinted designation card over the blank button designation card which comes with the voice terminal. This blank designation card can then be used as a substitute if, in the future, there are changes in features, telephone numbers, or extension assignments on the voice terminal.

ENVIRONMENTAL INFORMATION

In accordance with international environmental standards, parts of this Lucent Technologies voice terminal have been manufactured with recyclable plastic resins. These telephone parts have been marked >ABS< so they can be easily identified at recycling or waste recovery facilities when appropriate. The paper used in this documentation is also recyclable.

REFERENCES TO AT&T

Any references within this text to American Telephone and Telegraph Corporation or AT&T should be interpreted as references to Lucent Technologies Incorporated. The exception is cross-references to books published prior to December 31, 1996, which retain their original AT&T titles.

THE "CE" MARK

If the "CE" mark is affixed to this equipment, it means that it conforms to the European Union Electromagnetic Compatibility Directive (89/336/EEC) and the Low Voltage Directive (73/23/EEC).

WARNING

This is a Class A product as defined by EN55022:1998. In a domestic environment this product may cause radio interference, in which case the user may be required to take adequate measures.

RESPONSIBILITY FOR THE SYSTEM'S SECURITY

The system manager for each PBX system is responsible for the system's security. Lucent Technologies does not warrant that this product is immune from or will prevent unauthorized use of common-carrier telecommunication services or facilities accessed through or connected to it. Lucent Technologies will not be responsible for any charges that result from such unauthorized use. Product administration to prevent unauthorized use is the responsibility of the system manager, and he or she should read all documents provided with this product to fully understand the features available that may reduce the risk of incurring unauthorized charges.

TRADEMARKS

DEFINITY, QUORUM, and PassageWay are registered trademarks of Lucent Technologies. IBM is a registered trademark of International Business Machines Corporation.

WARRANTY

All terms and conditions specified in the owner's agreement with Lucent Technologies apply.

HEARING AID COMPATIBILITY

These voice terminals are Hearing Aid Compatible ("HAC"). In addition, some units have an "HAC" label on them.

IMPORTANT USER SAFETY INSTRUCTIONS

The most careful attention has been devoted to quality standards in the manufacture of your new voice terminal. Safety is a major factor in the design of every set. But, safety is YOUR responsibility too.

Please read carefully the helpful tips listed below and on the next page. These suggestions will enable you to take full advantage of your new voice terminal. Then, retain these tips for later use.

CAUTION: *This voice terminal is NOT for residential use. It is for business systems applications ONLY. Use in a residential environment could result in an electrical short circuit when the telephone wiring is set up to provide other applications, for example, for appliance control or power transformers. The AC power used in these applications may create a safety hazard by placing a direct short circuit across the telephone wiring.*

Use

When using your telephone equipment, the following safety precautions should always be followed to reduce the risk of fire, electric shock, and injury to persons.

- Read and understand all instructions.
- Follow all warnings and instructions marked on the telephone.
- This telephone can be hazardous if immersed in water. To avoid the possibility of electric shock, do not use it while you are wet. If you accidentally drop the telephone into water, do not retrieve it until you have first unplugged the line cord from the modular jack. Then, call service personnel to ask about a replacement.
- Avoid using the telephone during electrical storms in your immediate area. There is a risk of electric shock from lightning. Urgent calls should be brief. Even though protective measures may have been installed to limit electrical surges from entering your business, absolute protection from lightning is impossible.
- If you suspect a natural gas leak, report it immediately, but use a telephone away from the area in question. The telephone's electrical contacts could generate a tiny spark. While unlikely, it is possible that this spark could ignite heavy concentrations of gas.

- Never push objects of any kind into the equipment through housing slots since they may touch hazardous voltage points or short out parts that could result in a risk of electric shock. Never spill liquid of any kind on the telephone. If liquid is spilled, however, refer servicing to proper service personnel.
- To reduce the risk of electric shock, do not disassemble this telephone. There are no user serviceable parts. Opening or removing covers may expose you to hazardous voltages. Incorrect reassembly can cause electric shock when the telephone is subsequently used.

Service

1. Before cleaning, unplug the telephone from the modular wall jack. Do not use liquid cleaners or aerosol cleaners. Use a damp cloth for cleaning.
2. Unplug the telephone from the modular wall jack. Be sure to refer servicing to qualified service personnel when these conditions exist:
 - If liquid has been spilled into the telephone.
 - If the telephone has been exposed to rain or water.
 - If the telephone has been dropped or the housing has been damaged.
 - If you note a distinct change in the performance of the telephone.

SAVE THESE INSTRUCTIONS



When you see this warning symbol on the product, refer to this instructions booklet packed with the product for more information before proceeding.

IMPORTANT SAFETY WARNINGS FOR INSTALLATION

When this product is located in a separate building from the telephone communications system, a line current protector **MUST** be installed at the entry/exit points of **ALL** buildings through which the line passes. However, note that there is a difference between 4-wire and 2-wire installations.

The following are the **ONLY** acceptable devices for use in a 4-wire installation: (Note that two protectors are needed at each installation point.)

- Lucent Technologies 4-type protectors
- ITW LINX LP-type protectors

For 2-wire installations, the following is recommended: (Only one protector is needed at each installation point.)

- Lucent Technologies 4-type protectors
- ITW LINX LP-type protectors

However, if the above two protectors are not used, the following is acceptable in a 2-wire installation:

- Lucent Technologies 3BIC (Carbon block) or Lucent 3BEW (gas tube) protectors

NOTE: The 3BIC and 3BEW protectors can be used **ONLY** for 2-wire installations. They **CANNOT** be used for 4-wire installations.

WARNING: This voice terminal is **NOT** for residential use. It is for business systems applications **ONLY**. Use in a residential environment could result in an electrical short circuit when the telephone wiring is set up to provide other applications, for example, for appliance control or power transformers. The AC power used in these applications may create a safety hazard by placing a direct short circuit across the telephone wiring.

ADDITIONAL INSTALLATION WARNING

FAILURE TO FOLLOW THESE INSTRUCTIONS CAN CAUSE DAMAGE TO THE TERMINAL OR CAUSE THE ASSOCIATED PBX CIRCUIT PACK TO REMOVE POWER TO THE TERMINAL. IN EITHER CASE THE TERMINAL WILL NOT FUNCTION CORRECTLY.

The design of this product allows it to operate on either 2-wire or 4-wire DCP circuits. In order for the terminal to function properly in either 2-wire or 4-wire installations, there must be NO INTERCONNECTIONS between the wire pairs used for 2-wire and 4-wire operation. Bridging or paralleling of these pairs can result in damage to the terminal or can cause the PBX circuit pack to remove power to the terminal.

REMOVE ALL CONNECTIONS BETWEEN PAIRS BEFORE CONNECTING THE TERMINAL.

For 2-wire operation, if you need to plug the voice terminal into a 4-pin or 6-pin wall jack, instead of a standard 8-pin modular jack, refer to the "Line Interface" table below **Figure 1** in *The 8400-Series Voice Terminals Instructions for Installation, Switch Administration, and Programming the Options*, 555-110-725, to insure that the wires from the 4-pin or 6-pin wall jack are connected to the correct pins on the terminal "LINE" jack.

4-WIRE installations MUST ONLY have PBX connections on pair 2 and pair 3 and, if necessary, auxiliary power must be connected to pair 4.

2-WIRE installations MUST ONLY have PBX connections on pair 1 and, if necessary, auxiliary power must be connected to pair 4.

All of this information applies to all 8400 series voice terminals, the CALLMASTER III, and the 302B1 and 302C1 Attendant Console.

INSTALLING YOUR VOICE TERMINAL	1
Distance Limitations	1
Auxiliary Power	1
General Notes for Installation	2
Desktop Installation	2
Adjusting the 8405 and 8410 Voice Terminal Desktop Stand.	7
Wall Installation	9
Attaching Adjunct Equipment	12
USING THE RS-232-D JACK AND ANALOG	
ADJUNCT JACK ON THE 8411	14
PassageWay and Analog Adjunct Status Indications	
on the 8411	15
PassageWay Status Indications	16
Analog Adjunct Status Indications.	16
LABELING THE DESIGNATION CARD	17
For the 8403 Voice Terminal	17
For the 8405, 8410, and the 8411 Voice Terminals	17
For the 8434DX Voice Terminal	18
How to Label the Blank Designation Card	18
PROGRAMMING OPTIONS ON THE	
8411 VOICE TERMINAL	19
Selecting Whether the I-1 Channel or the I-2 Channel	
Will Be Used for the Analog Adjunct (For the 8411 Only)	19
Enabling/Disabling the Status Lights for the	
Analog (Tip/Ring) Adjunct Interface (For the 8411 Only)	20
Enabling/Disabling the Status Lights for the	
PassageWay Connection (For the 8411 Only)	22
OTHER 8400-SERIES VOICE TERMINALS	
DOCUMENTATION	22

INSTALLING YOUR VOICE TERMINAL

IMPORTANT: For a fuller description of installing the 8400-Series voice terminals and procedures on administering these sets and programming such options as enabling/disabling the speakerphone or one-way speaker, enabling/disabling the Mute function, selecting ringing preference, or selecting handset and speaker volume control, see the *8400-Series Voice Terminals Instructions for Installation, Switch Administration, and Programming the Options*, 555-015-725. (This document can be ordered from the Lucent Technologies BCS Publications Center at 1 800 457-1235.)

Distance Limitations

In **4-wire operation**, the voice terminal must be within 5,000 feet of the PBX using 22-gauge or 24-gauge wire, and within 4,000 feet of the PBX using 26-gauge wire.

In **2-wire operation**, the voice terminal must be within 5,500 feet of the PBX using 22-gauge wire, within 3,500 feet of the PBX using 24-gauge wire, and within 2,200 feet of the PBX using 26-gauge wire.

Auxiliary Power

In both a 4-wire or 2-wire configuration, most 8400-Series voice terminals are phantom powered from the PBX. However, you will need auxiliary power in the following instances:

- If you are using an 8411 or 8434DX voice terminal (*These sets require auxiliary power.*)
- If you have an 801A Expansion Module (used ONLY with the 8434DX voice terminal connected to a DEFINITY® Communications System G3V3.3 or later switch)
- If there is an attached adjunct equipment, such as an S201A Speakerphone

The following power supplies can be used with the 8400-Series voice terminals:

- Stand-alone 1151A1 Power Supply (PEC: 2404-010; Comcode: 107785693) and 1151A2 Power Supply with Battery Holdover (PEC: 2404-012; Comcode: 107785339)
- Stand-alone MSP-1 (PEC: 2404-010; Comcode: 406743419)
- 1145A Bulk Power Supply (PEC: 2404-011; Comcode: 106448939)
Battery for the 1145A (2.5 amp per hour battery)
(Comcode: 106448921)

- 1145B1 Bulk Power Supply (PEC: 2404-010)
Battery for the 1145B1 (2 amp battery = PEC: 24700;
or 5 amp battery = PEC: 24701)
- KS-22911 L2 (replaced by the MSP-1 Power Supply and 1151A1/A2 Power Supplies) — This power supply cannot be used with the 8411.

NOTES: The MSP-1, the 1151A1 and A2, and the 1145B are global power supplies.

It is recommended that the 1145A and the 1145B Bulk Power Supplies be used as auxiliary power for the 8434DX voice terminal. These power supplies provide battery back-up, and therefore when power outages occur, the 8434DX display will continue to operate.

If an 8434DX voice terminal with attached adjunct equipment is connected to an expansion module, it should be locally powered by an MSP-1 or an 1151A1 or A2. If this configuration is closet powered by an 1145A, two ports must be used. A KS-22911 L2 cannot be used in this situation.

General Notes for Installation

Regardless of which configuration is in use, ALL wiring between the PBX and the terminal MUST consist of twisted-pairs, including the modular line cord. The line cord must be a D8W, which consists of four twisted-pairs, or a Lucent Technologies approved equivalent.

Twisted-pair wiring is used to make lines less sensitive to crosstalk. Therefore, failure to use twisted pair wiring may result in less-than-optimum performance of the terminal and may also contribute to problems with the line.

An 8-wire modular cord MUST be used for all 4-wire and any 2-wire installations requiring auxiliary power.

You do NOT need to change any settings on the voice terminal for 2-wire or 4-wire installations. The voice terminal is able to detect whether it is in a 2-wire or a 4-wire configuration.

Desktop Installation

The following instructions are for a desktop installation. If you are mounting the voice terminal on the wall, proceed to the next section, “Wall Installation.”

NOTE: During the desktop installation procedure, refer to Figures 1, 2, 3, and 4 for the location of the jacks referred to in the following steps.

- Figure 1 shows the back of one of the 8403 voice terminal models. (Use this figure for installing the 8403, 8405, and 8410. However, note that the location of the jacks on the back of your voice terminal may differ slightly.)
- Figure 2 shows the back of the 8411 voice terminal, and Figure 3 shows the two jacks on the rear of the 8411. Use the RS-232-D jack for connecting a PC dedicated to PassageWay[®] Solution software and the Analog Adjunct

jack for connecting an analog device such as a modem, answering machines, fax machines, audio teleconferencing equipment, or TTY machines commonly used by the hearing impaired.

· Figure 4 shows the back of the 8434DX voice terminal. (Note that the jacks on the back of your voice terminal may be in a slightly different location.)

1. Turn the voice terminal face down on a flat surface.
2. If you are installing an 8405D, 8405D Plus, or 8410D voice terminal, refer to “Adjusting the 8405 and 8410 Voice Terminal Desktop Stand” for choosing whether the desktop stand should be in the high or low position. On the 8411, decide whether you want the kickstand in the up or the down position.

NOTE: Figure 1 shows the back of the 8403 voice terminal, although the location of the routing channels on some 8403 voice terminals and on the 8405 and 8410 may differ slightly from the 8403 shown in the figure. Also, the Handset jack on some 8403 voice terminals and on the 8405 and 8410 may be in a different location.

3. Snap one end of the line cord into the “LINE” jack and the adjunct cord (if applicable) into the Adjunct jack on the back of the voice terminal. (The Adjunct jack is labeled , except on the 8411, where it is labeled “ADJUNCT.”) For more information on installing adjuncts, refer to the section “Attaching Adjunct Equipment.”

IMPORTANT: If you are routing the cords on the 8405D, 8405D Plus, or 8410D voice terminal and the desktop stand is in the high position, you may need to place the cords through the long, rectangular opening that surrounds the jacks and plug the cords into the jacks BEFORE you insert the desktop stand onto the back of the voice terminal.

4. Thread the line cord (and adjunct cord, if applicable) through the routing channel leading to the top of the desktop stand, as shown in Figure 1 (on the 8403, 8405, and 8410 voice terminals), Figure 2 (on the 8411 voice terminal) and Figure 4 (on the 8434DX voice terminal). Note, however, that the location of the routing channels on some voice terminals may differ from those on the voice terminals in these figures. Make sure that each cord is placed securely under the square tabs in the routing channel.
5. If you are using an 8434DX with an attached 801A Expansion Module, plug the D6AP-87 cord, shipped with the expansion module, into the Expansion Module jack on the voice terminal (labeled “EX MOD”) and then plug the free end of the cord into the jack on the expansion module. The cord should be threaded through the routing channels on the 8434DX. See Figure 4. For more detailed instructions on installing the expansion module to the 8434DX, use the instructions titled “801A Expansion Module Instruction Manual,” shipped with the expansion module.

IMPORTANT: An 801A Expansion Module can be used ONLY with an 8434DX voice terminal connected to a DEFINITY G3V3.3 or later switch.

6. Snap one end of the coiled cord into the Handset jack. This jack is labeled . (On some 8403 voice terminals, you must thread the cord into the channel leading to the side edge of the voice terminal; the handset cord will then lead off the side of the voice terminal.)

WARNING: Do *not* insert the handset cord into the Adjunct jack. It may cause equipment damage.

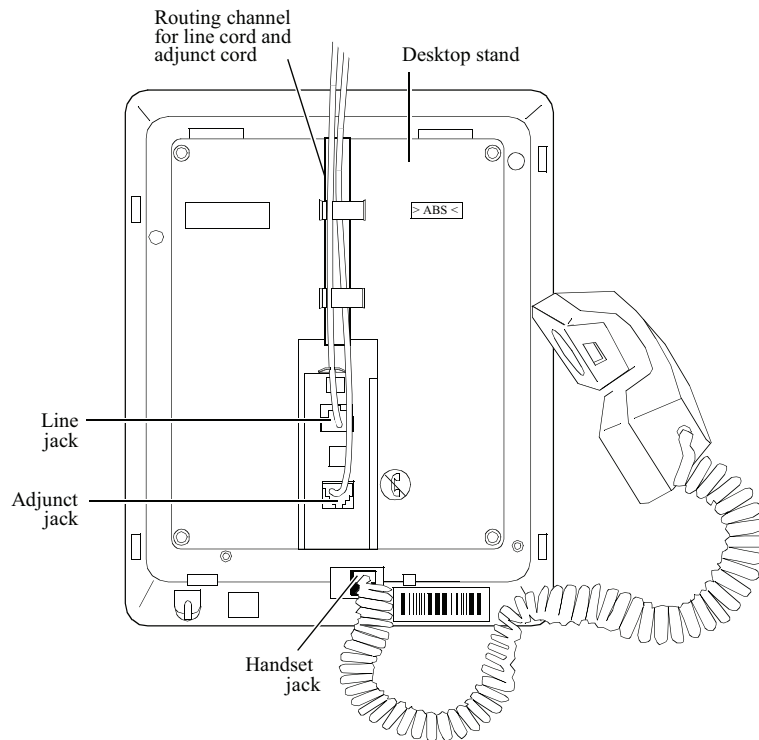

NOTE: The location of the jacks and the routing channel on the back of your voice terminal may differ slightly from the location shown in this figure.

FIGURE 1: Line, Adjunct, and Handset Cord Routing for Desktop Installation on the 8403, 8405, and 8410 Voice Terminals

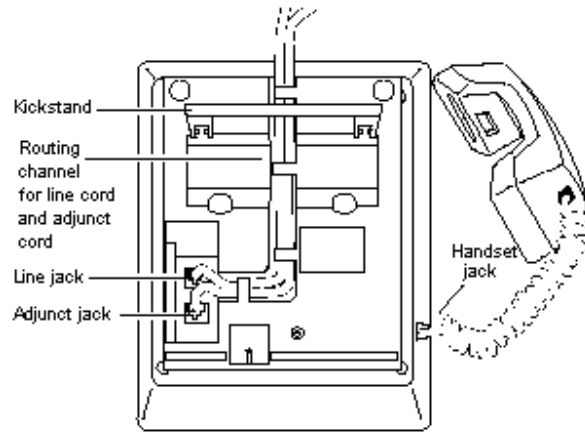

FIGURE 2: Line, Adjunct, and Handset Cord Routing for Desktop Installation on the 8411 Voice Terminal

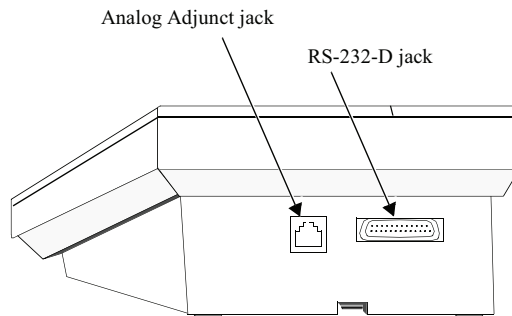
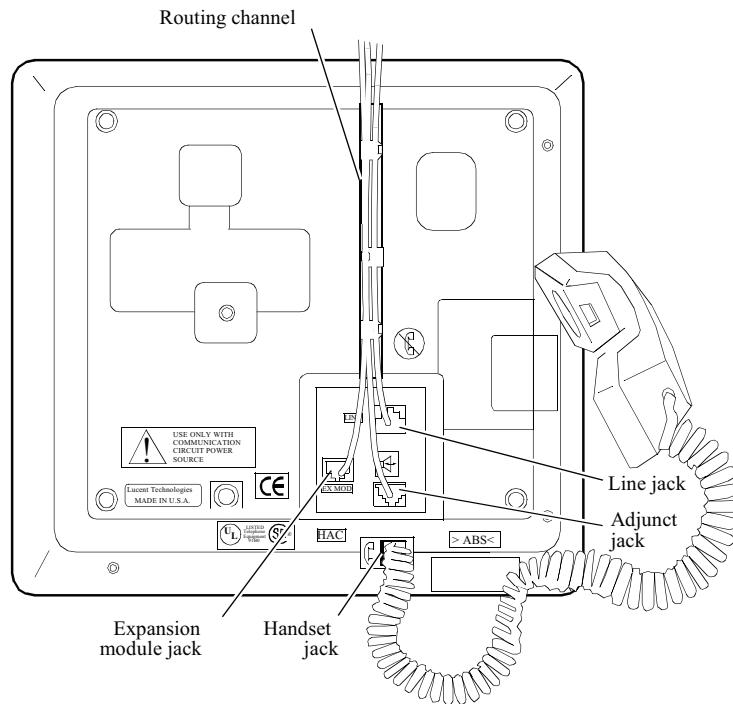

FIGURE 3: Connecting a PC for Use with PassageWay and Connecting an Analog Adjunct (These Jacks Are on the Rear of the 8411)



NOTE: The location of the jacks and the routing channel on the back of your voice terminal may differ slightly from the location shown in this figure.

FIGURE 4: Line, Adjunct, Handset, and Expansion Module Cord Routing on the 8434DX Voice Terminal

7. Turn the voice terminal right side up, with the front facing you.
8. Snap the free end of the handset cord into the handset and place the handset in the cradle.
9. Snap the free end of the line cord into the modular wall jack.
Refer to the section, "Attaching Adjunct Equipment" for information about connecting an 8400-Series voice terminal to the wall jack when an adjunct is used.
10. Lift the handset and listen for dial tone. If there is no dial tone, check all wire connections to make sure they are secure. Also, perform a self-test to see if the terminal is receiving power. (Press and hold down the **Test** button. If the light next to the button flashes rather than goes on steadily, it means the terminal is not able to communicate with the switch. If the Test light does not go

on, the voice terminal may not have power. In this case, check the connections and then verify that the particular voice terminal is administered on the DEFINITY switch.)

Adjusting the 8405 and 8410 Voice Terminal Desktop Stand

To provide better display visibility on the 8405D, 8405D Plus, and 8410D set, the desktop stand on these terminals can be installed in a high or low position. (When the voice terminal is shipped from the factory, the stand is in the low position.) Figure 5 shows you the set of tabs to use for each position.

NOTE: On the 8411 voice terminal, you can lift the kickstand on the back of the set to provide a better viewing angle of the terminal display.

Check which position (either the position of the desktop stand or the kickstand, according to the type of voice terminal you are using) allows the user the best viewing angle of the display, and then use the following short procedure for installing the desktop stand in the selected position.

To reinstall the desktop stand on the 8405D, 8405D Plus, or 8410D voice terminal for the low or the high position (See Figure 5.)

1. Place the lower desktop stand tab in the appropriate voice terminal tab slot.
2. Slowly lower the desktop stand until the top tab fits into the appropriate tab slot at the top of the voice terminal. You may need to press inward on the top of the desktop stand (see Figure 5) in order for the tab to fit into the slot.

NOTE: As noted before, if you choose to install the desktop stand in the high position, you may need to pass the cords through the long, rectangular opening that surrounds the jacks and then plug the cords into the jacks BEFORE you place the stand on the back of the voice terminal.

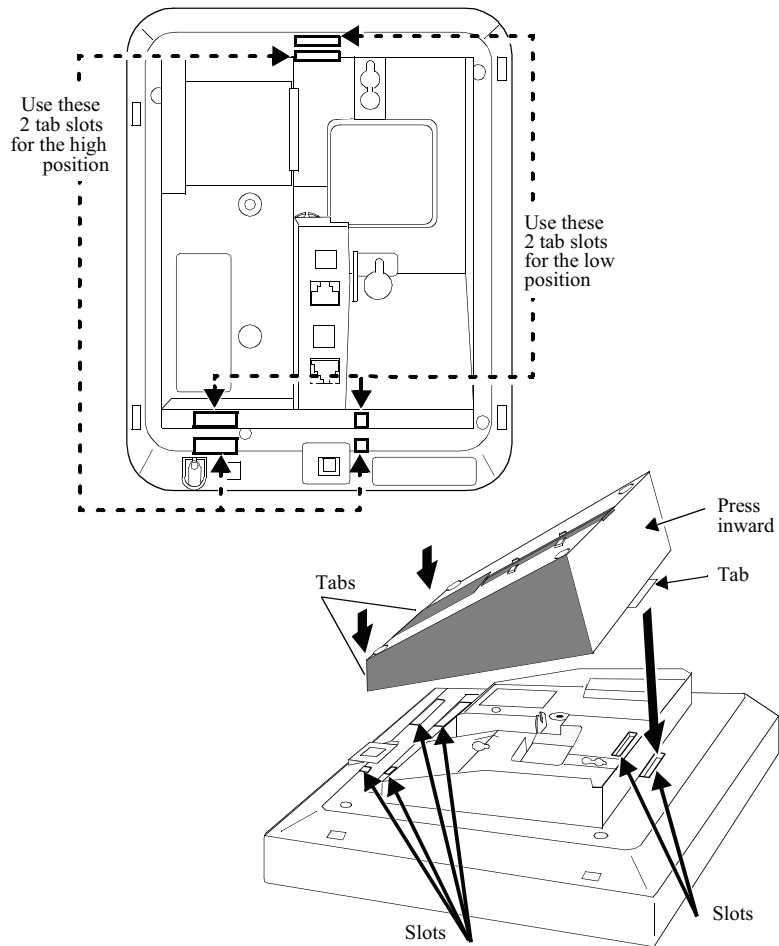

NOTE: The location of the slots may differ slightly from those in this figure.

FIGURE 5: Adjusting the 8405 and 8410 Desktop Stand

Wall Installation

NOTE: The 8403, 8405, and 8410 voice terminals can be wall-mounted. The 8411 and the 8434DX voice terminals CANNOT be wall-mounted.

For wall-mounting, you need a 1-foot D8W line cord (not supplied with the voice terminal; Comcode: 103786760).

To wall-mount the 8403, 8405, and 8410 voice terminals

1. Make sure the 8-conductor wall mount plate is in place.
2. Press down on the handset retainer hook located under the handset and slide it toward the top of the voice terminal. See Figure 6.
3. Rotate the hook and slide it back into its slot so the bottom part now sticks out from the top. Snap the hook firmly into place. See Figure 6.

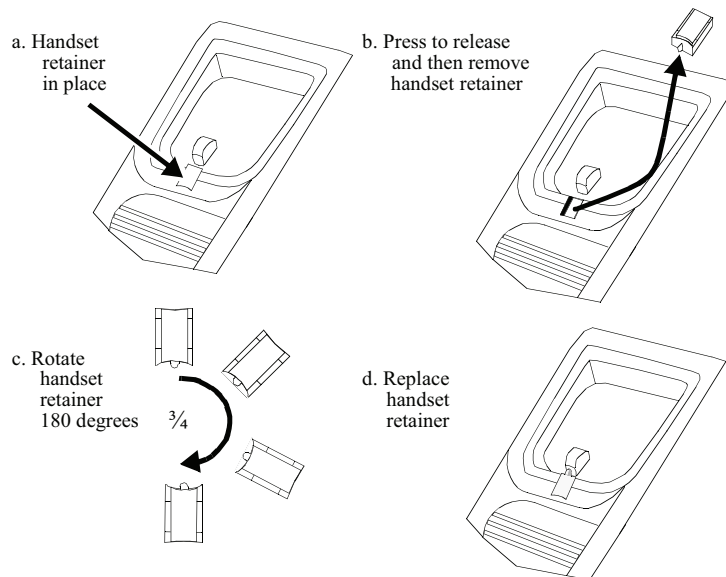

FIGURE 6: Reversing the Handset Hook

4. Place the voice terminal face down on a flat surface and turn the terminal face down.
5. Remove the desktop stand which is attached to the base of the voice terminal by tabs on the top and back of the stand. See Figure 7.
 - Press inward on the top of the stand until you can lift the top of the stand out of the tab slot on the voice terminal.
 - Lift the bottom of the stand out of the lower tab slot(s).

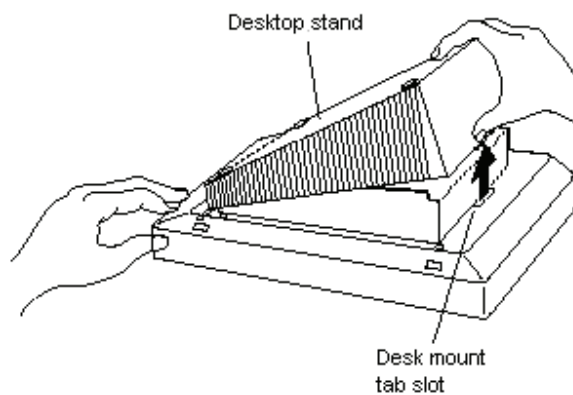



FIGURE 7: Removing the Desktop Stand on the 8403, 8405, and 8410

6. Snap the 1-foot line cord into the “LINE” jack in the back of the voice terminal.
 7. Pass the 1-foot line cord through the “Y”-shaped cord holder above the “LINE” jack, as shown on the back of the voice terminal in Figure 8. (On some voice terminals, you will need to pass the line cord through the channel located to the right of the “LINE” jack.) Coil any remaining part of the cord and place it in one of the recesses on the back of the voice terminal. (Again, see Figure 8.)
 8. Snap one end of the coiled cord into the Handset jack (labeled ) , as shown in Figure 8. (On some 8403 voice terminal models, you may need to thread the cord into the channel leading to the side edge of the voice terminal; the handset cord will then lead off the side of the voice terminal.)
- WARNING:** Do not insert the handset cord into the Adjunct jack. It may cause equipment damage.
9. Snap the free end of the 1-foot line cord into the wall jack.
 10. Place the base of the voice terminal on the wall-jack mounting studs, and pull downward until it is secure, as shown in Figure 8.

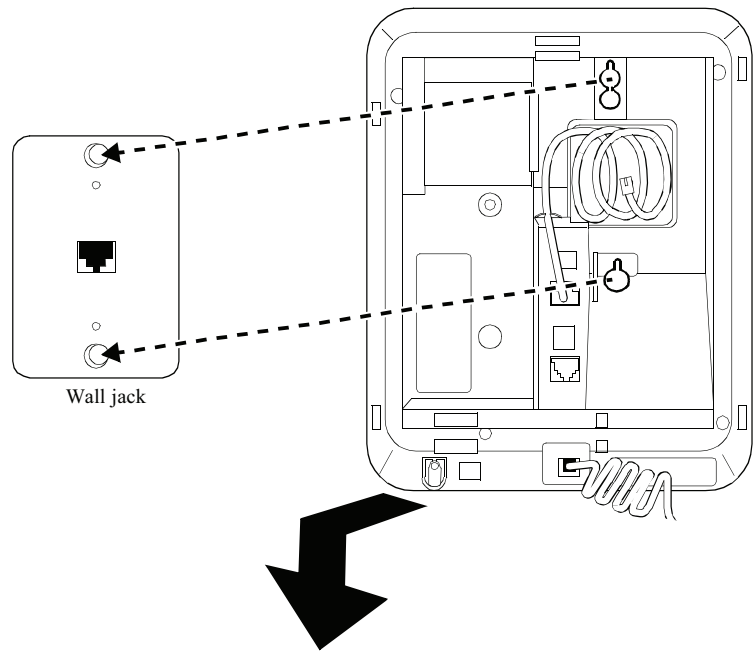

FIGURE 8: Placing the Voice Terminal onto the Wall Jack Mounting Studs

11. Snap the free end of the handset cord into the handset and place the handset in the cradle.

NOTE: The handset hook you repositioned will hold the handset in place.

12. Lift the handset and listen for dial tone. If there is no dial tone, check all wire connections to make sure they are secure. Also, perform a self-test to see if the terminal is receiving power. (Press and hold down the **Test** button. If the light next to the button flashes rather than goes on steadily, it means the terminal is not able to communicate with the switch. If the Test light does not go on, the voice terminal may not have power. In this case, check the connections and then verify that the particular voice terminal is administered on the DEFINITY switch.)

Attaching Adjunct Equipment

If you are installing a speakerphone (Lucent Technologies models S101A, S201A, or QUORUM® CS201A), a headset adapter (Lucent Technologies model 500A1), or other adjunct that may be offered, follow these steps to connect the adjunct equipment to your voice terminal.

The adjunct requires auxiliary power from either a local, individual power supply or a closet supply serving multiple phones. Refer to the adjunct's installation documentation for its power requirements.

1. Place the voice terminal face down on a flat surface.
2. Snap the adjunct cord into the Adjunct jack until you hear a click. (This jack is labeled , except on the 8411, where it is labeled "ADJUNCT.") See Figure 1 for the location of the Adjunct jack on the 8403, 8405, and 8410 voice terminals. See Figure 2 for the location of the Adjunct jack on the 8411 voice terminal. See Figure 4 for the location of the jack on the 8434DX voice terminals.
3. Refer to the "Desktop Installation" section for instructions on routing the adjunct cord through the channel.
4. Connect the free end of the adjunct cord to your speakerphone, headset adapter, or other adjunct.
5. Then, do one of the following:
 - If auxiliary adjunct power is provided by a bulk closet supply, connect the line cord from the voice terminal to the wall jack.
 - If a local, individual auxiliary power supply is being used, refer to Figure 9 for information about how to connect the telephone to the wall jack.

NOTE: If the voice terminal is being used with the 4-wire 7400B Plus or 2-wire 8400B Plus data module, the telephone line cord connects to the Phone jack on the 7400B Plus or 8400B Plus instead of to the wall jack. The Line connector on the 7400B Plus or 8400B Plus is then connected to the wall jack. Refer to the *7400B Plus Data Module User's Guide* or *8400B Plus Data Module User's Guide* for further information on using either of these data modules.

NOTE: The 7400B Plus or 8400B Plus data module cannot be used with the 8411 when the voice terminal is optioned for a second telephone number for the Analog Adjunct jack. Refer to the *7400B Plus Data Module User's Guide* or *8400B Plus Data Module User's Guide* for further information on using either of these data modules.

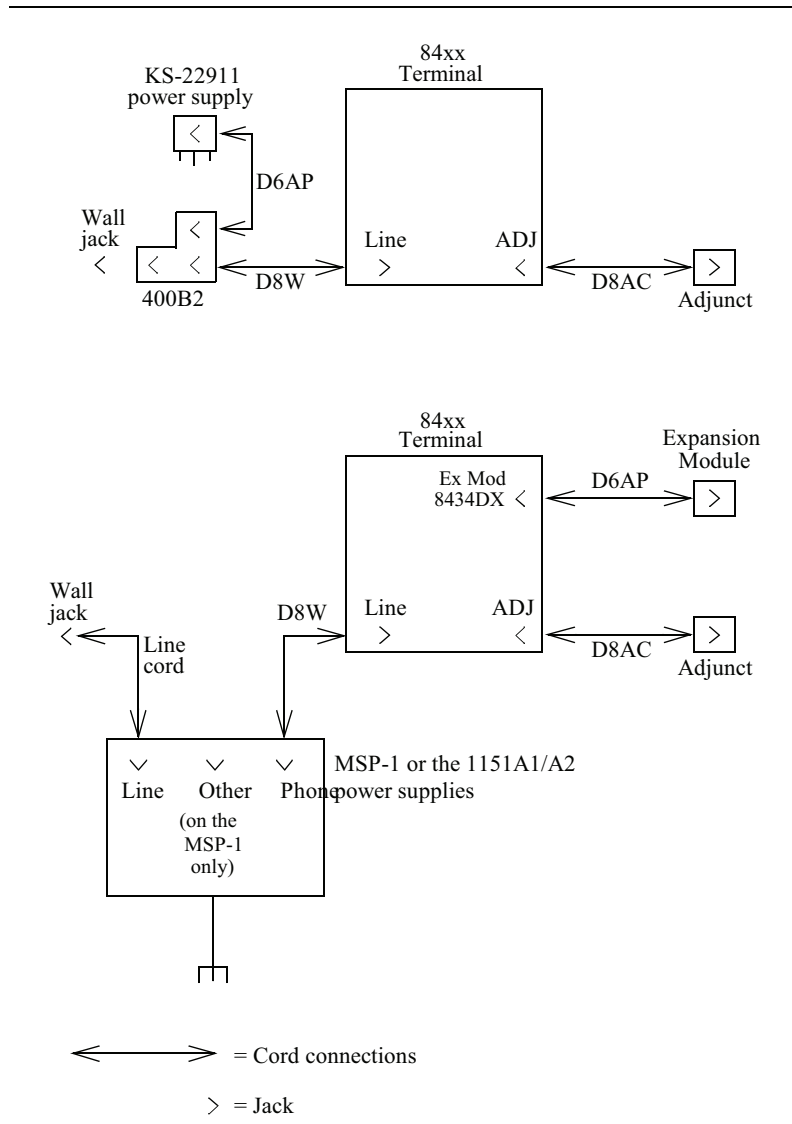

FIGURE 9: Connections for the 8434DX and All Telephones with Adjuncts Using an Individual Power Supply

USING THE RS-232-D JACK AND ANALOG ADJUNCT JACK ON THE 8411

See Figure 3 in the front of this manual for a drawing of the rear of the 8411 voice terminal. You can use the RS-232-D jack for connecting the 8411 to a PC for use with PassageWay Solution software. The Analog Adjunct jack can be used for connecting an answering machine, fax machine, modems, audio teleconferencing equipment or TTY machines commonly used by the hearing impaired.

Important Notes for the 8411

- Your 8411 *must* have auxiliary power, either locally using an MSP-1 or an 1151A1 or A2, or remotely using an 1145B1 closet supply.
- Before you set up your PassageWay connection, you must know which COM port number (that is, COM1, COM2, COM3, or COM4) to which you are connecting your 8411 voice terminal.
- On System 75 and System 85 switches, and a DEFINITY Generic 1, Generic 2, and Generic 3 prior to G3V4, Issue 3, the Analog Adjunct connected to the 8411 shares the telephone line with the voice terminal. Therefore, while the telephone is being used, you *cannot* use the Analog Adjunct at the same time, or vice versa. Beginning with DEFINITY G3V4, Issue 3, the telephone and Analog Adjunct can use separate telephone lines and thus the voice terminal and the Analog Adjunct can be used simultaneously.

To connect your 8411 to the PassageWay PC

1. Make sure that the PC is turned off.
2. Unplug the line cord from the modular wall jack or the auxiliary power supply, if necessary.
3. Connect one end of the 25-pin cord to the RS-232-D jack on the rear of the 8411 voice terminal.
4. Connect the other end of the cord to the serial (COM) port on the PC.
NOTE: You may need a 25-pin to 9-pin adapter in order to make this connection.
5. Connect, or reconnect, the line cord from the “LINE” jack on the voice terminal to the modular wall jack or the auxiliary power supply.
6. Turn on your PC.

For information about installing and setting up the PassageWay software, see the *PassageWay Direct Connection Solution For DEFINITY Communications System 8411 Voice Terminal User's Guide*, 585-201-115.

To connect an Analog Adjunct to the 8411

1. Connect the line cord of the Analog Adjunct to the Analog Adjunct jack on the rear of the 8411 voice terminal.

WARNING: Do NOT connect the Analog Adjunct to the wall jack. It will cause equipment damage.

NOTE: When an 8411 voice terminal is administered at a DEFINITY G3V4, Issue 3, switch, the voice terminal must be administered to use the appropriate analog telephone line. For more information on administration of the 8411, see “Switch Administration” later in this manual.

PassageWay and Analog Adjunct Status Indications on the 8411

The system manager may choose to administer Buttons #9 and #10 on the 8411 voice terminal, the last two buttons in the second column as shown in Figure 10, so that the lights next to these buttons show the status of the PassageWay connection (the PC can be connected to the RS-232-D jack on the rear of the 8411) and the status of the Analog Adjunct (this adjunct equipment can be connected to the Analog Adjunct jack also on the rear of the 8411).

NOTE: Button #9 is always used to monitor PassageWay, and Button #10 is always used to monitor the status of the Analog Adjunct.

IMPORTANT: At any time, you may use the Diagnostic feature (press **Shift** and then **Test** to enter Diagnostic Mode) to view the status light indications (next to Buttons #9 and #10) of the PassageWay and the Analog Adjunct connections.

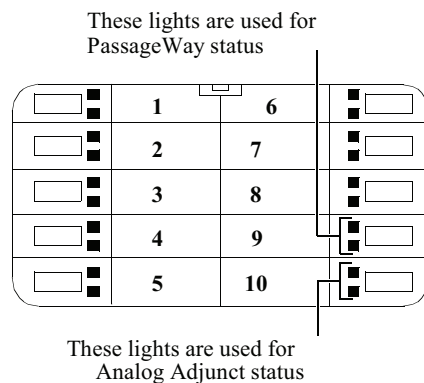

FIGURE 10: The location of Buttons #9 and #10 on the 8411

PassageWay Status Indications

On 8411 voice terminals, the GREEN and RED lights next to Button #9 provide the following status indications for the PassageWay connection:

PassageWay Status	Green Light	Red Light
AT Command Mode	Off	On
PassageWay Mode	On	Off
DCP Looparound	Flash*	Flash
Switch Link Down	Wink†	Wink
EIA Out-of-Sync	Flash	Off
Program Mode	On	Flash

* A *Flash* is a repeating pattern of 500 ms ON and 500 ms OFF.

† A *Wink* is a repeating pattern of 750 ms ON and 250 ms OFF.

Analog Adjunct Status Indications

On 8411 voice terminals, the GREEN and RED lights next to Button #10 provide the following status indications for the Analog Adjunct connection.

Analog Adjunct Status	Green Light	Red Light
The Analog Adjunct is off-hook	On	
The Analog Adjunct is on-hook and idle	Off	
The voice terminal is sending a ringing signal to the Analog Adjunct	Flash	
The Analog Adjunct is using the telephone line		On
The 8411 Voice Terminal is using the telephone line (that is, the Analog Adjunct is NOT using the line)		Off

NOTE: For the DEFINITY G3V4, Issue 3, or later switches, where the Data Options field is set for *analog* and the Analog Adjunct has been assigned its own telephone line, the RED light is always on.

LABELING THE DESIGNATION CARD

The designation card is a removable card placed behind a transparent protective cover on which the user can type or print call appearance or feature assignments. In most cases, the voice terminal's designation card is filled out before the user begins to use the set. *Do not discard the blank button designation card.* Instead, if there is a preprinted designation card, place it over the blank button designation card which comes with the voice terminal. The blank designation card can then be used as a substitute if, in the future, there are changes in features, telephone numbers, or extension assignments on the voice terminal.

The following information describes the designation card(s) for each voice terminal and explains how the cards are to be filled out, if necessary, and reinstalled under the plastic cover.

For the 8403 Voice Terminal

The designation card for the 8403 consists of two sections:

- The Feature Directory section — Provides a convenient quick reference list for 12 features. (These features can be accessed by pressing **Feature** and then entering the number assigned to the feature, 1 through 9, or 0, or the character * or #.) The system manager or user can print the name of the feature next to **F1** through **F9**, **F***, **F0**, and **F#**.
- The Call Appearance section — Sections **a**, **b**, and **c** are provided for noting the telephone number or extension of your voice terminal.

To label the card, use the instructions under “How to Label the Blank Designation Card” on the next page.

For the 8405, 8410, and the 8411 Voice Terminals

The Call Appearance/Feature Button Designation Card for the 8410 and 8411 voice terminal contains 10 spaces labeled **a** through **j** for specifying the telephone number, extension, or feature assigned to each button. The card for the 8405 has five spaces, labeled **a** through **e**.

NOTE: On the 8411, you may also label the telephone number card and place it under the telephone number card cover located beneath the handset.

To label the card, use the instructions under “How to Label the Blank Designation Card” on the next page.

For the 8434DX Voice Terminal

There are two Call Appearance/Feature Button Designation Cards for the 8434DX voice terminal:

- The smaller card contains two columns with five buttons in each column: the first column is labeled **a** through **e**; the second column is labeled **f** through **j**.
- The larger card also contains two columns with 12 buttons in each column. The button labels on this larger card are blank; that is, they are NOT pre-labeled with letters like the smaller card.

The four columns on the 8434DX voice terminal, totaling 34 button spaces, can be used for specifying the telephone number, extension, or feature assigned to each button.

To label the card, use the instructions under “How to Label the Blank Designation Card” below.

How to Label the Blank Designation Card

To label the designation card

NOTE: Be sure to print the voice terminal’s full telephone number, including the area code, on the first call appearance button.

1. The transparent cover is attached to the frame of the voice terminal by tabs on the top and bottom of the cover. Remove the cover by pulling the top tab forward and then lifting the bottom of the transparent cover from the voice terminal.
2. Print or type the desired labels on the blank designation card.
 - On the 8403, print or type the assigned features on your Feature Directory next to the appropriate number or character, and print or type the voice terminal user’s extension in Sections **a**, **b**, and **c**.
 - On the 8405, 8410, 8411, and 8434DX, print or type the voice terminal user’s extension on the call appearance buttons and the assigned features on the feature buttons.
3. Once you have SWITCH ADMINISTRATION

After you have successfully installed the voice terminal, the system manager can use the instructions in the *8400-Series Voice Terminals Instructions for Installation, Switch Administration, and Programming the Options*, 555-015-725, in order to administer selected features and assigned line appearances on each terminal. This manual also provides procedures for programming options such as enabling/disabling the speakerphone or speaker, enabling/disabling the Mute function, selecting ringing preference, and selecting handset and speaker volume control.

Note on 8411 Administration: When administering an 8411, remember the following:

- If a PC used for the PassageWay Solution software is connected to the 8411, type a “y” in the **PassageWay** field on the first administration screen.
- If an analog adjunct is connected to the 8411, type “analog” in the **Data Option:** field on the first administration screen.
- On the last administration screen, enter the appropriate information for the Analog Adjunct.

PROGRAMMING OPTIONS ON THE 8411 VOICE TERMINAL

Use the following procedures for selecting options for an 8411 voice terminal.

Selecting Whether the I-1 Channel or the I-2 Channel Will Be Used for the Analog Adjunct (For the 8411 Only)

If the 8411 is connected to a DEFINITY Generic 3, Version 4, Issue 3 (or later), the Analog (Tip/Ring) Adjunct and voice terminal can handle calls simultaneously over the I-1 Channel and the I-2 Channel. The system manager can administer the voice terminal to select which of the two channels the Analog (Tip/Ring) Adjunct will use.

NOTE: The following are reasons why you would change the factory setting for the Analog Adjunct from the I-2 Channel to the I-1 Channel:

- The voice terminal is connected to a DEFINITY switch before G3V4, Issue 3
- Anytime the 8411 voice terminal is NOT administered as an 8411B or 8411D
- If you need to use an analog device on the I-1 Channel

To select which channel (the I-1 Channel or the I-2 Channel) the Analog (T/R) Adjunct will use

1. While on-hook, press **Shift**.
 - The light next to **Shift** goes on.
2. Press **Mute**.
 - The light next to **Shift** goes off.
3. Enter the 2-digit code, “42” (“IC”).
 - The red light next to **Shift** flutters.
 - The current setting (either **T/R ON I1 CHANNEL** or **T/R ON I2 CHANNEL**) is shown on the display, if there is one.
4. Press either “1” or “2” to change the setting:
 - Press “1” to select the I-1 Channel for Analog Adjunct transmission
 - Press “2” to select the I-2 Channel for Analog Adjunct transmission

or if the voice terminal has a display, press ***** to change the setting. Press **#** to save the desired option and then exit programming.

 - After pressing “1” or “2” or pressing **#**, the light next to **Shift** goes off and one of the following voice terminal responses occurs:
 - If the voice terminal saves your selection, the first three green call appearance lights go on and, if you have a display, a confirmation message is displayed.
 - If the voice terminal cannot save this selection, the first three red call appearance lights go on and, if you have a display, an error message is displayed. In this case, the selected option will be in effect until power is removed from the set. If this happens, try repeating the process. If the option still cannot be saved, the terminal may be faulty.

Enabling/Disabling the Status Lights for the Analog (Tip/Ring) Adjunct Interface (For the 8411 Only)

If an Analog Adjunct has been connected to the Analog Adjunct jack on the rear of the 8411 voice terminal, the user can use the lights next to Button #10 (the last button in the second column) to see the status of the Analog Adjunct connection. These indications show:

- Status of the ringing signal being sent from the voice terminal to the Analog Adjunct (on OR off)
- Switchhook status of the Analog Adjunct (off-hook OR on-hook and idle)
- Status of the I-Channel (used by the Analog Adjunct OR by the 8411 voice terminal)

For a more detailed list of Analog Adjunct (Tip/Ring) status light indications, see “PassageWay and Analog Adjunct Status Indications on the 8411” earlier in this manual.

To enable or disable the status lights for the Analog Adjunct interface

1. While on-hook, press **Shift** .
 - The light next to **Shift** goes on.
2. Press **Mute** .
 - The light next to **Shift** goes off.
3. Enter the 2-digit code, “25” (“AL”).
 - The red and green lights next to Button #10 flutter.
 - The current setting (**ENABLE T/R STATUS LAMPS** or **DISABLE T/R STATUS LAMPS**) is shown on the display, if there is one.
4. Press either “1” or “2” to change the setting:
 - Press “1” to enable the status lights for the Analog (Tip/Ring) Adjunct connected to the Analog Adjunct jack
 - Press “2” to disable status lights for Analog Adjunct connection (so the button is thus used in the normal way, that is, for call appearance or feature indications)

or if the voice terminal has a display, press ***** to change the setting. Press **#** to save the desired option and then exit programming.

- After pressing “1” or “2” or pressing **#** , the light next to **Shift** goes off and one of the following voice terminal responses occurs:

If the voice terminal saves your selection, the first three green call appearance lights go on and, if you have a display, a confirmation message is displayed.

If the voice terminal cannot save this selection, the first three red call appearance lights go on and, if you have a display, an error message is displayed. In this case, the selected option will be in effect until power is removed from the set. If this happens, try repeating the process. If the option still cannot be saved, the terminal may be faulty.

Enabling/Disabling the Status Lights for the PassageWay Connection (For the 8411 Only)

If a PC for the PassageWay Solution has been connected to the RS-232-D jack on the rear of the 8411, the user can use Button #9 (the next-to-last button in the second column) to see the status of the PassageWay connection. For a list of PassageWay indications, see “PassageWay and Analog Adjunct Status Indications on the 8411” earlier in this manual.

To enable or disable the status lights for the PassageWay connection

1. While on-hook, press **Shift**.
 - The light next to **Shift** goes on.
2. Press **Mute**.
 - The light next to **Shift** goes off.
3. Enter the 2-digit code, “79” (“PW”).
 - The red and green lights next to Button #9 flutter.
 - The current setting (**ENABLE PWY STATUS LAMPS** or **DISABLE PWY STATUS LAMPS**) is shown on the display, if there is one.
4. Press either “1” or “2” to change the setting:
 - Press “1” to enable the status lights for the PassageWay connection (next to Button #9)
 - Press “2” to disable the status lights for the PassageWay connection

or if the voice terminal has a display, press ***** to change the setting. Press **#** to save the desired option and then exit programming.

- After pressing “1” or “2” or pressing **#**, the light next to **Shift** goes off and one of the following voice terminal responses occurs:

If the voice terminal saves your selection, the first three green call appearance lights go on and, if you have a display, a confirmation message is displayed.

If the voice terminal cannot save this selection, the first three red call appearance lights go on and, if you have a display, an error message is displayed. In this case, the selected option will be in effect until power is removed from the set. If this happens, try repeating the process. If the option still cannot be saved, the terminal may be faulty.

OTHER 8400-SERIES VOICE TERMINALS DOCUMENTATION

The following documentation provides instructions for using both the fixed and the switch features. These documents can be ordered from the Lucent Technologies BCS Publications Center.

Write: Lucent Technologies BCS Publications Center
P.O. Box 4100
Crawfordsville, IN 47933

Call: 1 800 457-1235
Outside US: 1 317 361-5353

When ordering any of these documents, be sure to specify the title and the “555” ordering number.

- *8400-Series Voice Terminals Instructions for Installation, Switch Administration, and Programming the Options*, 555-015-725
- *DEFINITY Communications System Generic 1 and Generic 3 and System 75 8403 Voice Terminal User’s Guide*, 555-230-761
- *DEFINITY Communications System Generic 1 and Generic 3 and System 75 8403 Voice Terminal Quick Reference Guide*, 555-230-762
- *DEFINITY Communications System Generic 2 and System 85 8403 Voice Terminal User’s Guide*, 555-104-761
- *DEFINITY Communications System Generic 2 and System 85 8403 Voice Terminal Quick Reference Guide*, 555-104-762
- *DEFINITY Enterprise Communications Server (ECS) Release 5 8405 Voice Terminal User’s Guide*, 555-230-736
- *DEFINITY Enterprise Communications Server (ECS) Release 5 8405 Voice Terminal Quick Reference Guide*, 555-230-737
- *DEFINITY Communications System Generic 2 and System 85 8405 Voice Terminal User’s Guide*, 555-104-726
- *DEFINITY Communications System Generic 2 and System 85 8405 Voice Terminal Quick Reference Guide*, 555-104-725
- *DEFINITY Communications System Generic 1 and Generic 3 and System 75 8410 Voice Terminal User’s Guide*, 555-230-763
- *DEFINITY Communications System Generic 1 and Generic 3 and System 75 8410 Voice Terminal Quick Reference Guide*, 555-230-764
- *DEFINITY Communications System Generic 2 and System 85 8410 Voice Terminal User’s Guide*, 555-104-763
- *DEFINITY Communications System Generic 2 and System 85 8410 Voice Terminal Quick Reference Guide*, 555-104-764
- *DEFINITY Enterprise Communications Server (ECS) Release 5 8411 Voice Terminal User’s Guide*, 555-230-872
- *DEFINITY Enterprise Communications Server (ECS) Release 5 8411 Voice Terminal Quick Reference Guide*, 555-230-873
- *DEFINITY Communications System Generic 2 and System 85 8411 Voice Terminal User’s Guide*, 555-104-769

- *DEFINITY Communications System Generic 2 and System 85*
8411 Voice Terminal Quick Reference Guide, 555-104-770
- *DEFINITY Communications System Generic 1 and Generic 3 and System 75*
8434DX Voice Terminal User's Guide, 555-230-856
- *DEFINITY Communications System Generic 1 and Generic 3 and System 75*
8434DX Voice Terminal Quick Reference Guide,
555-230-857
- *DEFINITY Communications System Generic 2 and System 85*
8434DX Voice Terminal User's Guide, 555-104-767
- *DEFINITY Communications System Generic 2 and System 85*
8434DX Voice Terminal Quick Reference Guide, 555-104-768
- **801A Expansion Module Instruction Manual**, 555-015-136
- *PassageWay Direct Connection Solution for DEFINITY*
Communications System 8411 Voice Terminal User's Guide,
585-201-115.



Lucent Technologies
Bell Labs Innovations

Copyright © 1997 Lucent Technologies
All Rights Reserved